

J-Bar Setting	
A	Pinion:
B	Frame:
C	Length:

Measure from the ground up.
C DIM is the center to center of your J-Bar

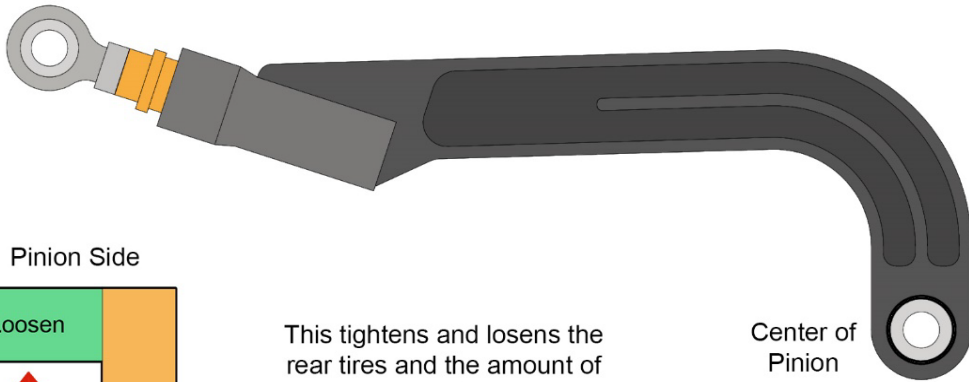

Frame Side Pinion Side

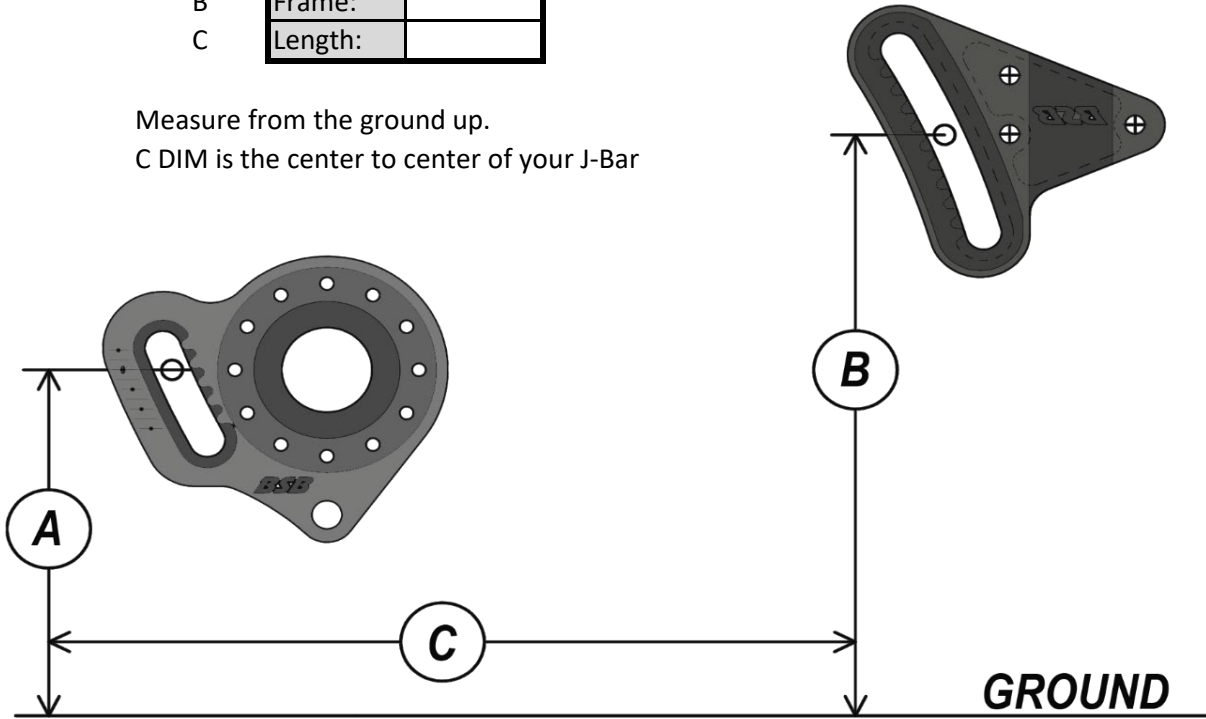
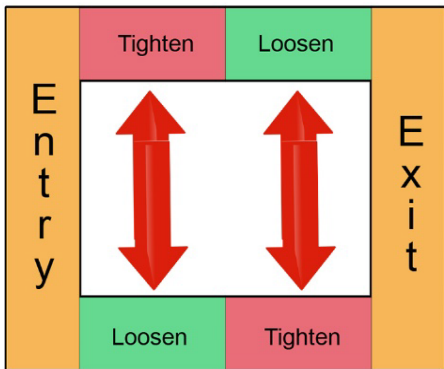

This tightens and loosens the rear tires and the amount of slip they have.

Start at center of pinion with a 6" to 7" split. Measure from ground up and subtract the difference.